

■ PRODUCT DRAWING

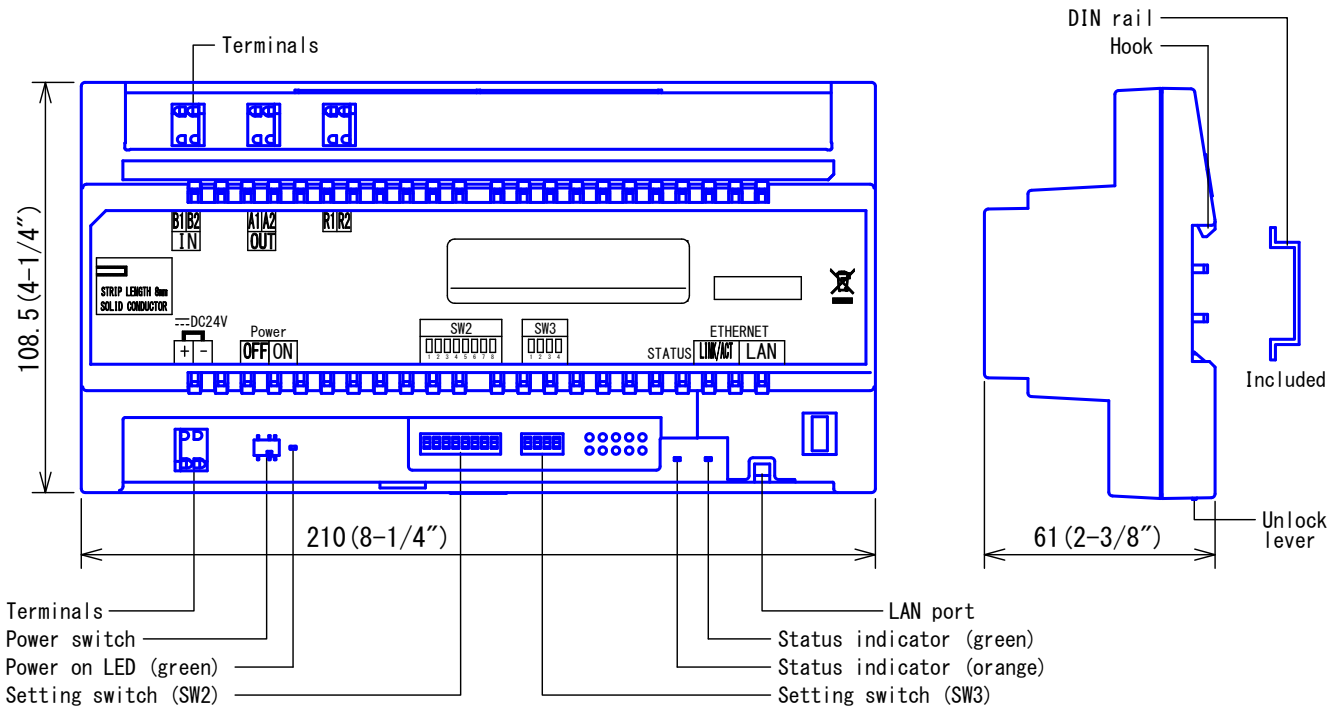

● MOUNTING

- Mounting on wall surface

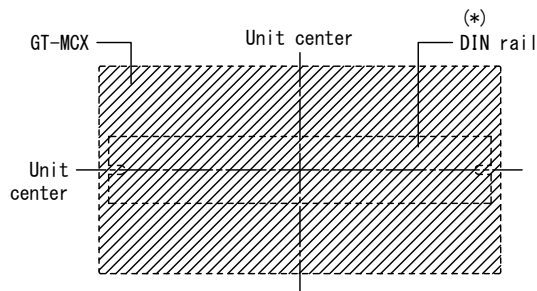

* DIN rail: Included with the unit

DESCRIPTION MULTI-BUILDING CONTROL UNIT	FIG. NAME PRODUCT DRAWING	UNIT mm	DATE 31 May, 2017
MODEL NO. GT-MCX	FIG. NO. G55639-1-5	PAGE 1/5	REVISION 1
			AIPHONE

■ SPECIFICATIONS

Power source	DC 24V. Supplied from a power supply unit(PS-2420 etc.)																																								
Power consumption	Standby 75mA, Maximum 115mA																																								
Ambient temperature	0~40°C (32~104° F)																																								
Mounting	DIN rail																																								
Material	Self-extinguishing ABS resin																																								
Capacity	<table border="1"> <tr> <td colspan="2">Standard system</td> </tr> <tr> <td colspan="2">Tenant section</td> </tr> <tr> <td colspan="2">Max. 24 sections</td> </tr> <tr> <td colspan="2">Entrance station: Max. 4 per section</td> </tr> <tr> <td colspan="2">Guard station: Max. 1 per section</td> </tr> <tr> <td colspan="2">Residential/tenant station: Max. 48 per section (GT-1D: max. 100)</td> </tr> <tr> <td colspan="2">Main section</td> </tr> <tr> <td colspan="2">Max. 8 sections</td> </tr> <tr> <td colspan="2">Entrance station: Max. 4 per section</td> </tr> <tr> <td colspan="2">Guard station: Max. 1 per section</td> </tr> <tr> <td colspan="2">Expanded system</td> </tr> <tr> <td colspan="2">Tenant section</td> </tr> <tr> <td colspan="2">Max. 24 sections</td> </tr> <tr> <td colspan="2">Entrance station: Max. 15 (Common trunk line 1: max. 7 Common trunk line 2: max. 8) per section</td> </tr> <tr> <td colspan="2">Guard station: Max. 3 (Common trunk line 1: max. 1, Common trunk line 2: max. 2) per section</td> </tr> <tr> <td colspan="2">Residential/tenant station: Max. 500 per section, Max. 5,000 per system</td> </tr> <tr> <td colspan="2">Main section</td> </tr> <tr> <td colspan="2">Max. 8 sections</td> </tr> <tr> <td colspan="2">Entrance station: Max. 15 (Common trunk line 1: max. 7 Common trunk line 2: max. 8) per section</td> </tr> <tr> <td colspan="2">Guard station: Max. 3 (Common trunk line 1: max. 1, Common trunk line 2: max. 2) per section</td> </tr> </table>	Standard system		Tenant section		Max. 24 sections		Entrance station: Max. 4 per section		Guard station: Max. 1 per section		Residential/tenant station: Max. 48 per section (GT-1D: max. 100)		Main section		Max. 8 sections		Entrance station: Max. 4 per section		Guard station: Max. 1 per section		Expanded system		Tenant section		Max. 24 sections		Entrance station: Max. 15 (Common trunk line 1: max. 7 Common trunk line 2: max. 8) per section		Guard station: Max. 3 (Common trunk line 1: max. 1, Common trunk line 2: max. 2) per section		Residential/tenant station: Max. 500 per section, Max. 5,000 per system		Main section		Max. 8 sections		Entrance station: Max. 15 (Common trunk line 1: max. 7 Common trunk line 2: max. 8) per section		Guard station: Max. 3 (Common trunk line 1: max. 1, Common trunk line 2: max. 2) per section	
Standard system																																									
Tenant section																																									
Max. 24 sections																																									
Entrance station: Max. 4 per section																																									
Guard station: Max. 1 per section																																									
Residential/tenant station: Max. 48 per section (GT-1D: max. 100)																																									
Main section																																									
Max. 8 sections																																									
Entrance station: Max. 4 per section																																									
Guard station: Max. 1 per section																																									
Expanded system																																									
Tenant section																																									
Max. 24 sections																																									
Entrance station: Max. 15 (Common trunk line 1: max. 7 Common trunk line 2: max. 8) per section																																									
Guard station: Max. 3 (Common trunk line 1: max. 1, Common trunk line 2: max. 2) per section																																									
Residential/tenant station: Max. 500 per section, Max. 5,000 per system																																									
Main section																																									
Max. 8 sections																																									
Entrance station: Max. 15 (Common trunk line 1: max. 7 Common trunk line 2: max. 8) per section																																									
Guard station: Max. 3 (Common trunk line 1: max. 1, Common trunk line 2: max. 2) per section																																									
LAN	Ethernet 100BASE-TX (IEEE802.3 and ANSI×3.263 standards)																																								
Protocol	IPv4, IPv6, TCP, UDP, IGMP, MLD, DHCP, NTP, DNS, etc.																																								
Encryption method	TLS1.2																																								
Weight	340g (approx.) (0.75 lbs)																																								
Unit color	Middle gray(N6.4 Munsell Approximation)																																								

DESCRIPTION	FIG. NAME	UNIT	DATE
MULTI-BUILDING CONTROL UNIT	SPECIFICATIONS	mm	31 May, 2017
MODEL NO.	FIG. NO.	PAGE	REVISION
GT-MCX	G55639-2-5	2/5	1
			AIPHONE

WIRING DIAGRAM

[Multi building consisting of standard system]

Tenant section/Main section

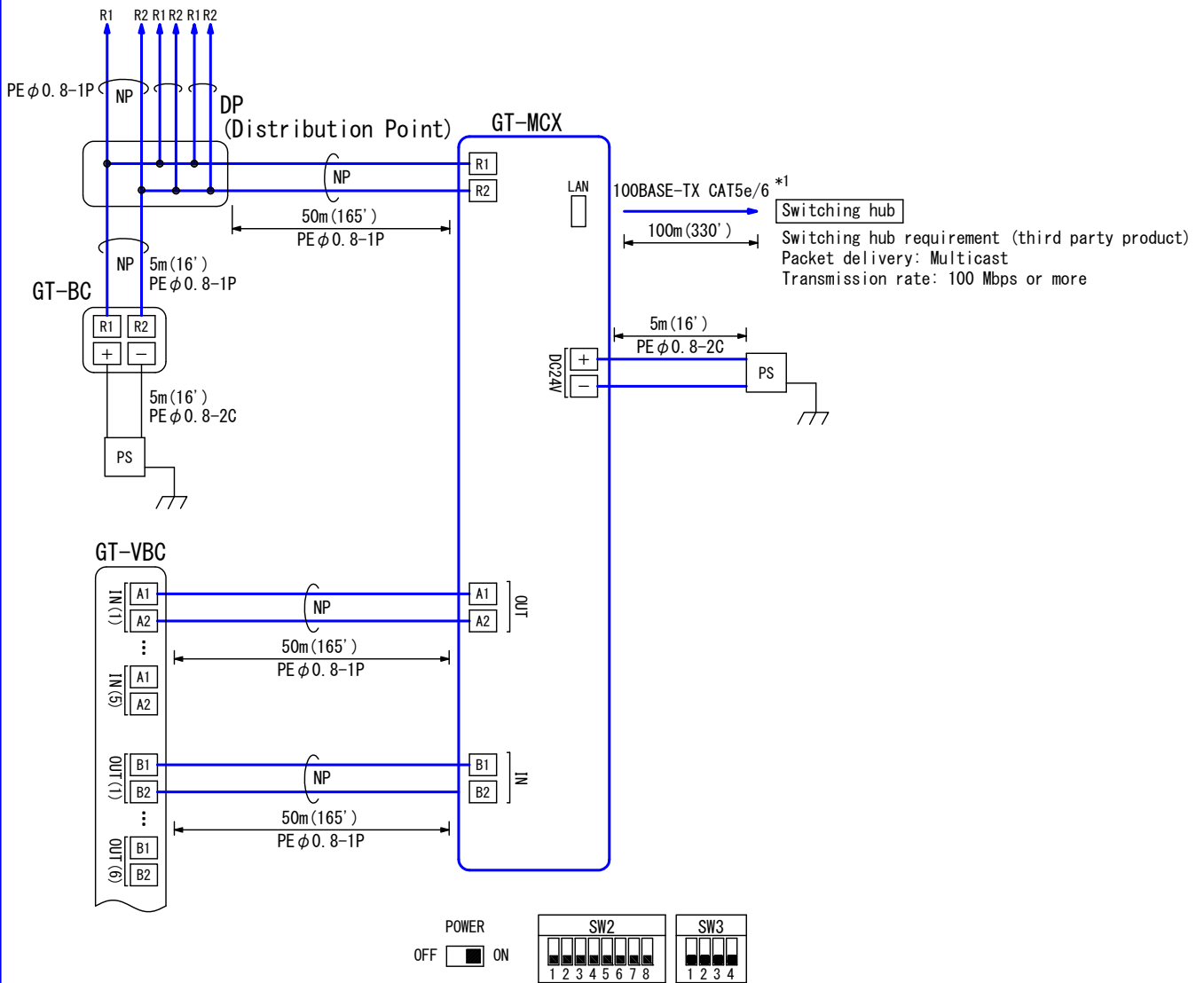

PS: PS-2420/S/UL/BF/DM

PE: Polyethylene-insulated PVC jacket cable

*1: Do not route a CAT5e/6 cable outdoors from a multi-building control unit directly. When routing a CAT5e/6 cable outdoors from a switching hub, use a model that supports outdoor wiring.

DESCRIPTION MULTI-BUILDING CONTROL UNIT	FIG. NAME WIRING DIAGRAM	UNIT mm	DATE 31 May, 2017
MODEL NO. GT-MCX	FIG. NO. G55639-3-5	PAGE 3/5	REVISION 1
			AIPHONE

【Multi building consisting of expanded system】

Tenant section/Main section

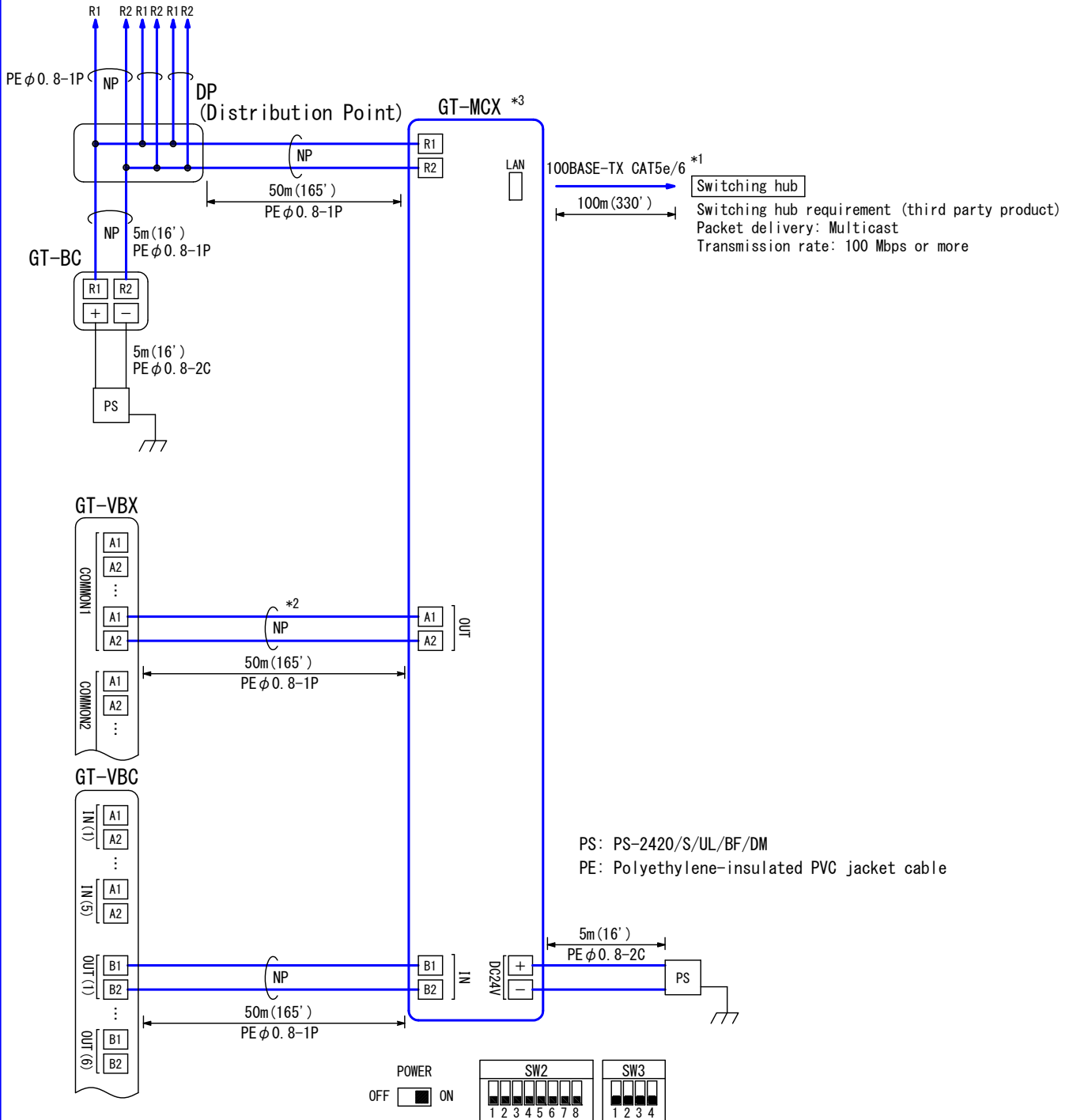

- *1: Do not route a CAT5e/6 cable outdoors from a multi-building control unit directly. When routing a CAT5e/6 cable outdoors from a switching hub, use a model that supports outdoor wiring.
- *2: GT-MCX must be connected to the common trunk line 1.
- *3: One GT-MCX is needed per section.

DESCRIPTION	FIG. NAME	UNIT	DATE
MULTI-BUILDING CONTROL UNIT	WIRING DIAGRAM	mm	31 May, 2017
MODEL NO.	FIG. NO.	PAGE	REVISION
GT-MCX	G55639-4-5	4/5	1

AIPHONE

■ RESTRICTIONS

- A main section cannot include residential/tenant stations.
- Only all-in-one type entrance stations can be used in a main section. Modular type entrance stations cannot be used.
- Each pair of wires should be in a separately jacketed cable (audio, video, and power wiring).
- Mounting location shall be accessible or servicing (never in such a place as attic, etc.)
- A computer is required to make system settings.
- ID1 is unavailable for the entrance station and the guard station. (ID1 of each station is used for GT-MCX in a multi building system.)

■ FUNCTIONS

- Control both data signals and audio signals for all communications between the main sections' stations and the tenant sections' stations.
- All sections can be configured via IP network connection.

■ SETTING

- Section ID setting (Tenant sections #1 to #24, Main sections #25 to #32.....SW2-2~6
- Reset the passcode (OFF/ON).....SW2-8
- DHCP setting (OFF/ON).....SW3-1
- Setting initialization (OFF/ON).....SW3-2

DESCRIPTION MULTI-BUILDING CONTROL UNIT	FIG. NAME RESTR. /FCN. /SETTING	UNIT mm	DATE 31 May, 2017
MODEL NO. GT-MCX	FIG. NO. G55639-5-5	PAGE 5/5	REVISION 1
			AIPHONE