

WIRING DIAGRAM

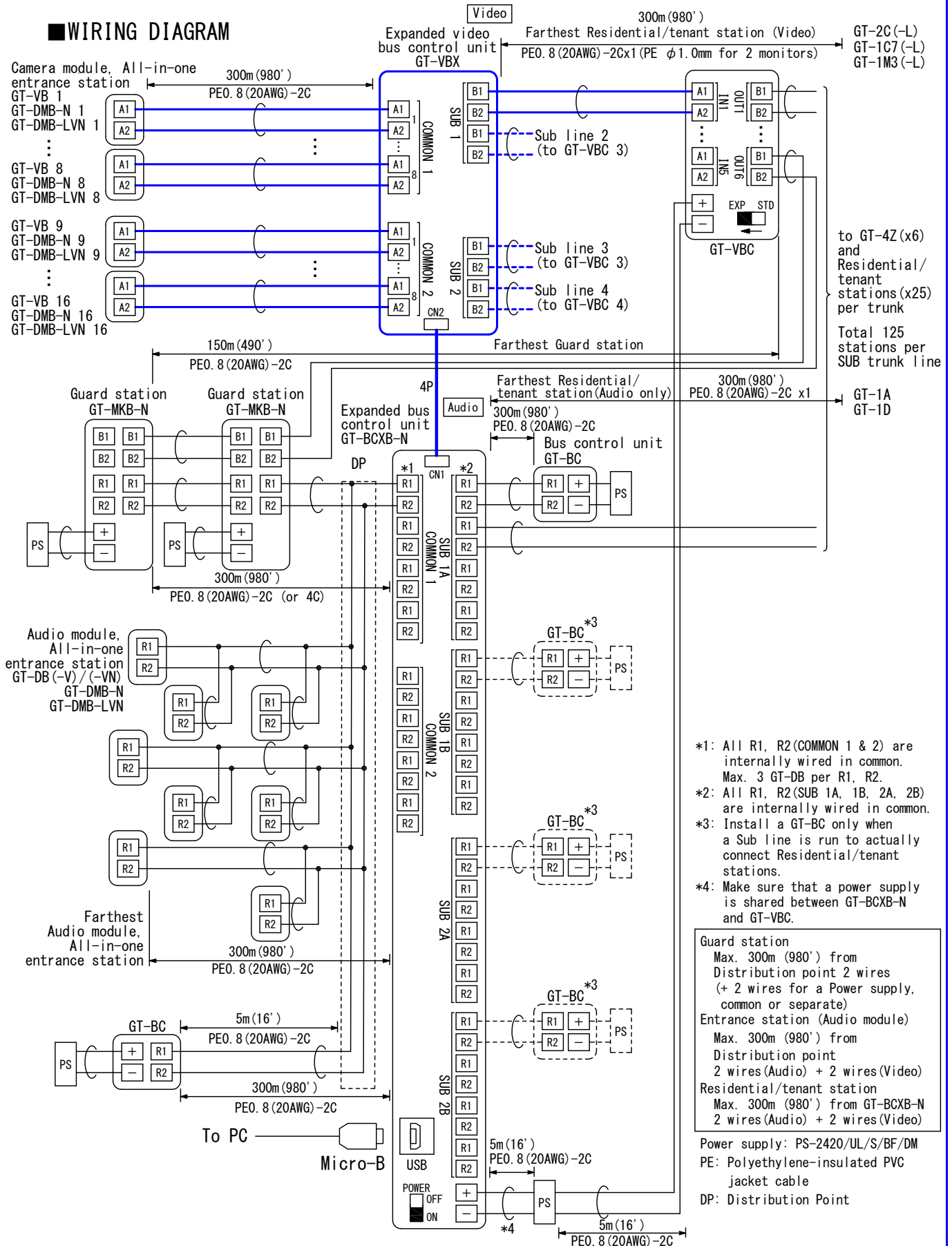

DESCRIPTION	FIG. NAME	UNIT	DATE
EXPANDED VIDEO BUS CONTROL UNIT	WIRING DIAGRAM	mm	11 July, 2017
MODEL NO.	FIG. NO.	PAGE	REVISION
GT-VBX	G57589-2-3	2/3	2

AIPHONE

